

# Generation II<sup>®</sup>

Exterior Cladding Systems  
H3.2 Environmentally Sustainable  
MicroPro<sup>®</sup> Treatment



VERSION V1 01/03/2018

NATURAL. DURABLE. CLASSIC.

PROUDLY MADE IN NZ BY



# Table of Contents

DISCLAIMER.....	2
1.0 SCOPE .....	3
1.1 INTENDED USE .....	3
1.2 PRODUCT INFORMATION .....	3
2.0 USE OF THE KLC GENERATION II VERTICAL SHIPLAP WEATHERBOARD PROFILES.....	4
3.0 LIFE SERVICEABILITY.....	7
4.0 CARE AND SITE STORAGE .....	8
4.1 On-Site Storage.....	8
4.2 Handling .....	8
5.0 GUIDELINES FOR INSTALLATION .....	9
5.1 Pre-Installation Checks.....	9
5.2 Installation.....	9
5.3 Framing .....	9
5.4 Nail Selection .....	10
6.0 INSTALLATION DETAILS FOR VERTICAL SHIPLAP WEATHERBOARDS..	11
6.1 Fixing Detail for Direct Fix Application .....	11
6.2 Fixing Detail for Cavity Fix Application.....	13
6.3 Bottom of Cladding .....	14
6.4 Wall Penetration .....	14
6.5 Window and Door Heads .....	15
6.6 Cutting and End Sealing .....	15
6.7 Soakers and Flashings .....	16
6.8 Box Corners for External Corners .....	17
6.9 Internal Corners.....	17
6.10 General Inter-Storey Junctions.....	17
7.0 FASCIA INSTALLATION.....	18
8.0 PAINTING REQUIREMENTS .....	19
9.0 MAINTENANCE.....	20
10.0 HEALTH AN SAFETY .....	21
11.0 DETAILED DRAWINGS SECTION.....	22

## DISCLAIMER

The recommendations contained in this document are based on good building practice, but are not an exhaustive statement of all relevant information. The successful performance of the system relies on many factors outside the control of KLC Limited, such as the quality of workmanship and design. KLC Limited will not be responsible for the installation of the products outside of the control of KLC Limited. It is the responsibility of the building designer of the intended project to ensure that the details and recommendations provided are suitable and that the design is executed appropriately.

# 1 Scope

## 1.1 INTENDED USE

The information contained within this guide are based on good building practice and are not a complete statement of all relevant building practices.

Including:

- NZS 3602:2003 Timber Wood Based Products
- NZS 3617:1979 Specification for profiles of weatherboards, fascia boards and flooring
- AS/5068 Finger Joints in Structural Products
- AS/5069 Finger Joints in Non-Structural Products
- NZS 1328.1:1998 Glued Laminated Structural Timber

Meets and Exceeds:

- NZS 3640:2003 Preservation of timber and wood based products

## 1.2 PRODUCT INFORMATION

KLC Generation II H3.2 products are manufactured from short lengths of clear high grade radiata pine that are finger-jointed together using a structural glue to produce an untreated length of 6.3metres (substrate). The substrate is then treated to H3.2, using the revolutionary water based micronised copper timber treatment technology called "MicroPro". The blanks are then kiln dried (KD) to a pre-determined moisture content. The KD H3.2 substrate is then profiled to various Weatherboards, Fascia, Finishing Boards (D4S), box corners and other profiles. To complement these appearance grade products, a dual coat alkyd priming system is applied. Generation II H3.2 MicroPro® treated products provide protection from termites, borers, and fungal decay, and are backed by Koppers Performance Chemicals 50 year treatment guarantee. ([www.kopperspc.co.nz](http://www.kopperspc.co.nz)).

KLC will not "Warranty" any Generation II H3.2 product that has not been stored correctly and installed by a professional Licenced Building Practitioner and as per the NZ Building Code and painted in accordance with AS/NZS 2311 2009.

## 2 Use of KLC Generation II Vertical Shiplap

KLC Generation II H3.2 Vertical profiles have been designed for use in residential and small commercial building applications. The weatherboards are a thickness width of 18mm and are available in a range of face profiles.

The KLC Generation II H3.2 vertical profiles are an Acceptable Solution in E2/AS1 for direct fix only. However horizontal cavity battens can be used for cavity fix as an Alternative Solution.

Options are:

### a. H3.2 Castellated cavity battens

H3.2 Castellated cavity battens have gaps machined into them at approximately 80mm centres. They have a downward beveled slope on the top at an 18 degree angle to assist draining water. They are to be fixed onto every nog/dwang using 40x2.5 galvanised flat head nails or 50mm galvanized brad nails.

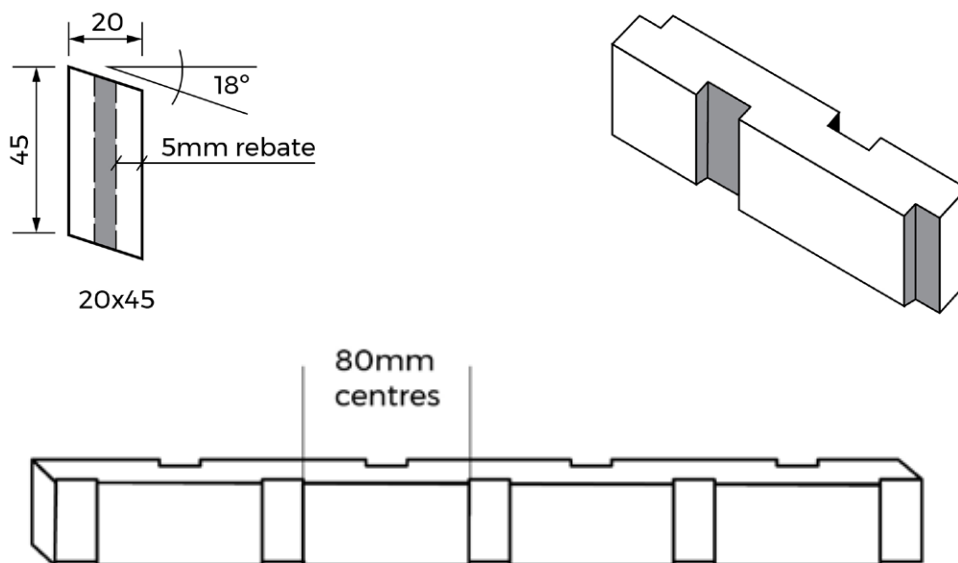

### b. Cavibat

Cavibat is an extruded polypropylene fluted cavity batten. Cavibat's are installed with 40.2.8mm galvanized flat head nails or brad gun nailed with galvanized brads at 400 centres. Please refer to Cavibat's technical guide for full installation details.



## 2 Use of KLC Generation II Vertical Shiplap

KLC Generation II H3.2 Vertical Shiplap profiles can be used for buildings that fall within the scope of NZS3604 Timber Framed Buildings and Acceptable Solutions E2/AS1.

Although timber weatherboards can be used on buildings that have a maximum Weathertightness Risk Matrix Score of 20, you will need to use Acceptable Solutions E2/AS1 Table 3.0 to ascertain the use of direct fix or on a cavity fixing system.

All types of weatherboard profiles may be used in low risk buildings. Only bevel back, rusticated and vertical shiplap weatherboards should be used in high risk buildings. For information on requirements for rained ventilated cavities refer to the Acceptable Solution E2/AS1, paragraph 9.1.8.

Weatherboard cladding systems are an acceptable solution under the terms of the New Zealand Building Code E2/AS1. NZBC E2/AS1 section 1.5 specifies that the design, installation and alteration of cladding is classed as restricted building work.

The KLC Generation II cladding products must be installed by a Licenced Building Practitioner (LBP)

### VERTICAL SHIPLAP PROFILES

KLC35 135x18	KLC59 180X18
KLC58 135x18	KLC54 180X18
KLC 51 135X18	KLC56 180X18
KLC53 135X18	KLC57 180X18
	KLC60 180X18

#### KLC35 V Shiplap

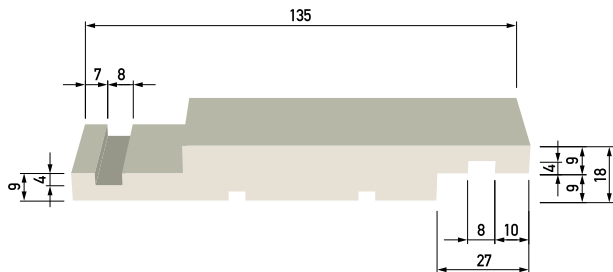

#### KLC58 V Shiplap Centre Groove

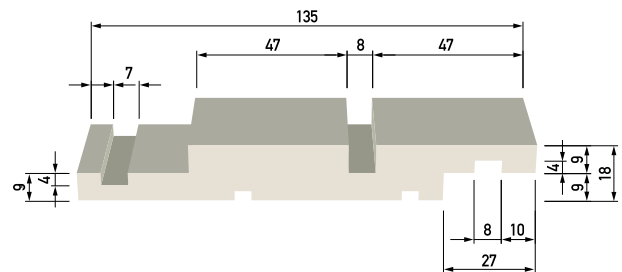

#### KLC51 Bevelled Edge V Shiplap

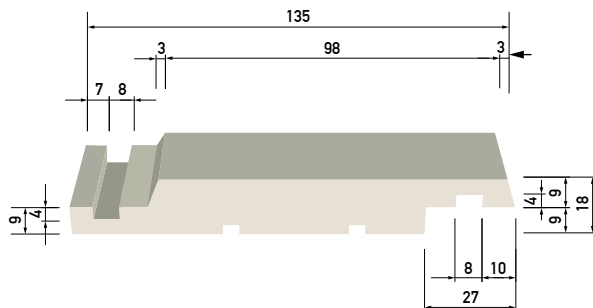

#### KLC53 Bevelled Edge V Shiplap Centre Groove

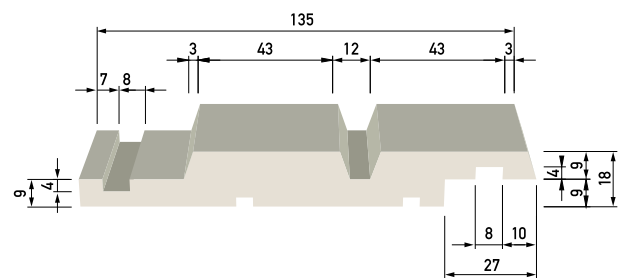

## 2 Use of KLC Generation II Vertical Shiplap

KLC59 V Shiplap Centre Groove

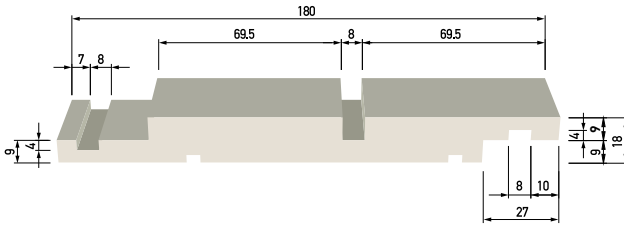

KLC54 Bevelled Edge V Shiplap Centre Groove

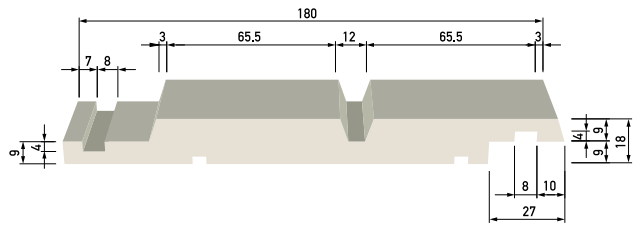

KLC56 V Shiplap

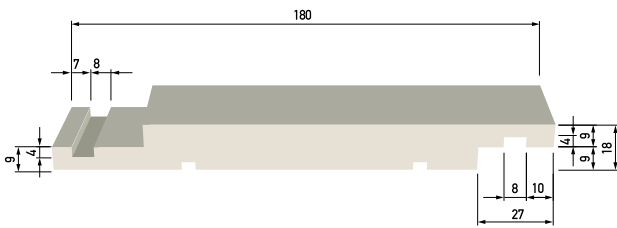

KLC57 Bevelled Edge V Shiplap Double Centre Groove

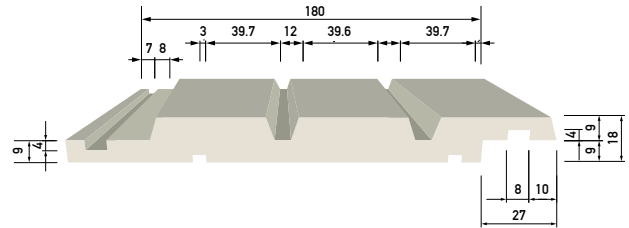

KLC60 V Shiplap Double Centre Groove

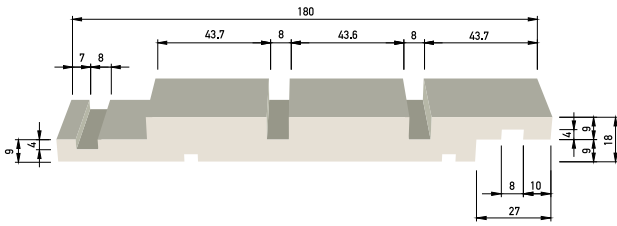

# 3 Life Serviceability

KLC Generation II weatherboards have a durability warranty based on the Treatment Manufacturer's 50 year limited guarantee.

Under the New Zealand Standards NZS 3602:2003 Weatherboards and cladding products must have a minimum durability of 15 years.

The life service is subject to correct installation, paint coating of the product, maintenance and care.

When KLC Generation II weatherboards are installed according to the instructions contained in this manual and by a Licenced Building Practitioner (LBP) or suitably qualified person, the service life can be expected to be considerably longer.

Full details covering all the aspects of pre-installation care, installation, painting and maintenance are contained within this manual.

# 4 On-Site Storage

To avoid exposure to the elements in all seasons.

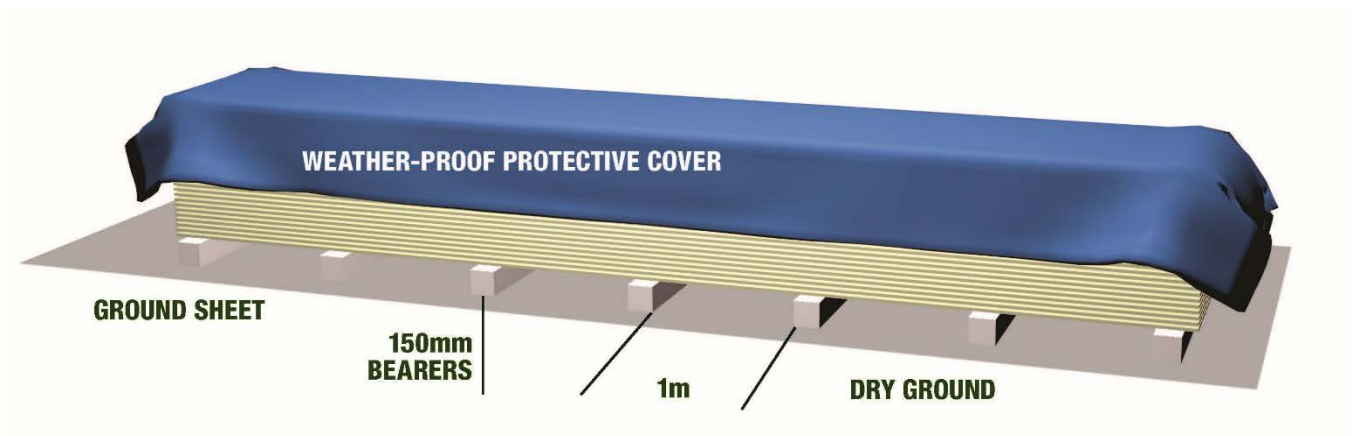

## 4.1 ON-SITE STORAGE

Correct on-site storage of KLC Generation II products prior to installation is critical.

- KLC Generation II products are made from kiln dried timber. Timber will absorb moisture in a damp environment, and release it in a dry environment.
- Store in a dry, well ventilated area.
- Store on a flat surface 150mm above the ground, supported every metre along the length of the product.
- Protect from the elements including direct sunlight and rain.
- If stored outside, there must be a moisture barrier (ground sheet) under the stack.
- If KLC Generation II H3.2 products do absorb moisture prior to installation, dimensional swelling may occur, this will disappear when the timber returns to its original moisture content.

## 4.2 HANDLING

- Care should be taken when unloading KLC Generation II product. The profiles should be unloaded by hand or if unloaded by mechanical means, ensure that there is a minimum of 2 well-spaced load points to avoid excessive bending or sag during unloading.
- Always carry profiles products on their edge and avoid leaning against any vertical surface to avoid any bending.



# 5 Guidelines for Installation

The products should be installed by a competent qualified person in accordance with the provisions of the Building Code E2/AS1 (sec 9.4) and NZS 3604 (2011). For further information visit BRANZ Good Practice Guide, Timber Cladding.

## 5.1 PRE INSTALLATION CHECKS

There are many simple checks that should be carried out prior to installation which can avoid issues during installation.

- Where any KLC Generation II profile has been exposed to moisture prior to installation, the moisture content should be checked. If the moisture content is above 15% then the product should not be installed until it returns to 15% or less.
- When excessive moisture or swelling is found the profile should be put aside and allowed to dry to its original profiled dimensions. This is best done by placing the product in fillet and stored as outlined above. Filleting allows air movement through the boards for drying.
- Check for any defects or damage caused during delivery or storage.
- Remove any dirt, dust or stones which may be on the product.
- If there are any areas where a primer coat has been removed or damaged, the affected area should be sanded smooth and a primer coat applied.
- This product is primed with a factory applied alkyd architectural coating, a similar oil-based undercoat or primer must be used for touch-up work
- If building in “sea spray or geothermal zones”, it is the building designers responsibility to ensure all specified fastenings, fittings, and flashings comply with NZS 3604, Section 4 – Durability.

## 5.2 INSTALLATION

- Installation must be by a Licensed Building Practitioner (LBP), or supervised by an LBP. Please refer to BRANZ Bulletin Number 468, Fixing of Timber Weatherboards.
- Do not install Generation II H3.2 weatherboards if their moisture content is over 15%.
- If building in “seaspray or geothermal zones”, it is the building designers responsibility to ensure all specified fastenings, fittings, and flashings comply with NZS 3604, Section 4 – Durability.
- Avoid joining KLC Generation II H3.2 vertical weatherboards use full length boards whenever possible, ensure a good pre-set out to use full lengths.
- Use full length boards.
- Re-prime all cut ends, mitres, notching's, borings with 2 coats of brush-applied alkyd primer.
- Stud centres are at 600mm max, Nog centres at 450mm max.
- Leave a 2mm minimum expansion gap in the lap of rebated Shiplap profiles, to allow for expansion and contraction.
- Boards must be fixed to allow for seasonal movement, with an overlap of 32mm minimum for Shiplap profiles.

## 5.3 FRAMING

The timber framing must comply with NZS3604 – Timber Famed Buildings with maximum of 600mm centres.

- The moisture content of the framing must not exceed 20% at the time of fixing the weatherboard. Excessive moisture content in the timber framing may cause movement in the framing structure thus altering the weatherboard positioning.
- Additional framing may be required at soffit, corners, windows and door opening

# 5 Guidelines for Installation

## 5.4 NAIL SELECTION

KLC Generation II H3.2 weatherboards are treated using the revolutionary water based micronised copper timber treatment technology called “MicroPro”.

- In most applications both stainless steel and hot dip galvanised steel fixings and fasteners are safe to use with MicroPro® treated exterior products. Compliant to AS/NZS 4680 and to NZBC E2/AS1 Table 24.
- Note In sea-spray and Geothermal zones nails must be Stainless Steel.
- Hand nailing is recommended as the use of nail guns can cause fibre damage to the face and back of the board.

Based on MicroPro® ISANTA fastener corrosion test results, MicroPro® treatment is considered similar to CCA treatment with regard to the effects on fastener material. Therefore, in most applications both stainless steel and hot dip galvanised steel fixings and fasteners are safe to use with MicroPro® treated exterior products. Compliant to AS/NZS 4680 and to NZBC E2/AS1 Table 24.

Fixings are to comply with E2/AS1 Table 24

## NAILING SCHEDULE

WEATHERBOARD	FRAMING SET-OUT	NAILS (DIRECT FIXING)	NAILS (ON CAVITY)	NAILING REQUIREMENTS	WIND ZONE	WIND BARRIER*
Vertical Shiplap Weatherboards	Studs @ 600mm centres max. Nog centres at 450 mm	75mm x 3.15mm Jolt Head (JH) Hot Dipped Galvanised Nails or Stainless Steel Nails 35mm penetration into the board	90mm x 3.15mm Jolt Head (JH) Hot Dipped Galvanised Nails or Stainless Steel Nails 35mm penetration into the board	Single nail on every nog 35mm from side edge of the board	Low, Medium, High & Very High	Lightweight Building Paper Heavyweight Building Paper
External & Internal Corners Box Corners	All weatherboards	50x2.5mm Jolt Head (JH) Hot Dipped Galvanised Nails 250mm centres	50x2.5mm Jolt Head (JH) Stainless Steel Nails 250mm centres	300mm centres maximum		
<b>Note:</b> Hot dip galvanising must meet the requirements of AS/NZS4680:2006. In Expose Zone D (refer to NZS 3604 paragraph 4.2.3) all fixings must be type 316 stainless steel						

# 6 Installation Details for Generation II

## 6.1 FIXING DETAILS FOR DIRECT FIX APPLICATION

KLC Generation II H3.2 Vertical Weatherboards can be directly fixed to the framing but the use of this is limited by section 3.3 of E2/AS1. All types of weatherboards can be used where the risk score is between 0 and 6.

Where weatherboards are directly fixed to the framing a wall underlay complying with Table 23 of E2/AS1 sections 9.1.5-9.1.7 shall be installed prior to fixing.

Refer to detailed drawings section

- Hand nailing is recommended as nail guns can cause damage to the surface of the board. If a nail gun is used, a non-marking attachment should be used to avoid damage to the surface.
- Use 75 x 3.15 Hot Dipped Galvanised or Stainless Steel nails for fixing KLC Generation II H3.2 vertical weatherboards. Nails must have a minimum penetration of 35mm in to the wall framing. Refer to BRANZ Bulletin 468 and E2/AS1 for complete list of fixing options.
- Nail holes should be pre-drilled especially in areas around joints and the end of boards. This is to avoid splitting the product. Pre-drill all boards 50mm from the end to avoid end splitting.
- Avoid joining vertical weatherboards use full length boards whenever possible, follow pre-set out to use full lengths.
- Pre-drill all boards to a minimum of 1mm diameter smaller than nail gauge.
- Single nail all weatherboard profiles, regardless of size. Nailing boards together will likely result in split boards.
- Location of nails is approximately 35mm to the side edge of the board. **Do not** nail through the underneath board. Aligning the weather grooves.
- Nails should be applied at an upward angle of 10 degrees to avoid water entering through the fixing point.
- All nails should be punched to a depth of no less than 2mm.
- As soon as nails are punched below the surface of the weatherboard they must be filled with an exterior grade filler immediately to prevent moisture uptake in the weatherboards.
- Re-prime all cut ends, mitres, notching's, borings with 2 coats of brush-applied alkyd (oil based) primer.
- Timber weatherboards are designed to accommodate thermal, seismic and moisture related movement in the boards laps. Each weatherboard is single nailed so that the weatherboards can expand, contract and move independently of each other. KLC does not recommend the use of any sealant/glue which inhibits the natural and ongoing movement of the weatherboard.

## JOINTS AND CUTS

All cut ends, drill holes, rebates and notches must be resealed immediately with a suitably approved product. eg an Alkyd Primer (oil-based)

End sealing can also be achieved by the application of 2 coats of brush-applied, quality Alkyd (oil based) primer which are allowed to dry between coats.

When products are joined a scarf or splay join is to be used. These must face away from the prevailing weather. Alternatively, a corrosion- resistant soaker must be applied.

# 6 Installation Details for Generation II

## D3.6 Vertical Shiplap Direct Fixing Detail

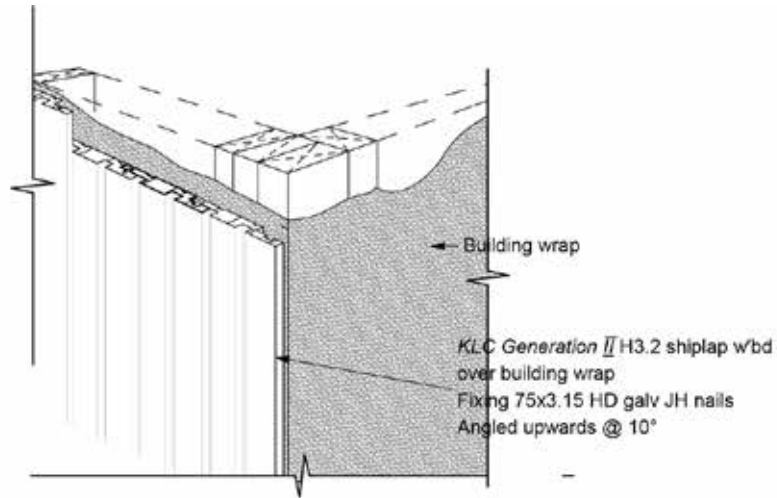

# 6 Installation Details for Generation II

## 6.2 FIXING DETAILS FOR CAVITY FIX APPLICATION

- Hand nailing is recommended as nail guns can cause damage to the surface of the board.
- Use 90 x 3.15 Hot Dipped Galvanised or Stainless-Steel nails for fixing KLC Generation II H3.2 vertical weatherboards.
- Nails must have a minimum penetration of 35mm in to the wall framing through the cavity batten. Refer to BRANZ Bulletin 468 and E2/AS1 for complete list of fixing options.
- Avoid joining vertical weatherboards use full length boards whenever possible, follow pre-set out to use full lengths.
- Pre-drill all boards to a minimum of 1mm diameter smaller than nail gauge.
- Single nail all weatherboard profiles, regardless of size. Nailing boards together will likely result in split boards.
- Location of nails is approximately 35mm to the side edge of the board. **Do not** nail through the underneath board. Aligning the weather grooves.
- Nails should be applied at an upward angle of 10 degrees to avoid water entering through the fixing point.
- All nails should be punched to a depth of no less than 2mm.
- As soon as nails are punched below the surface of the weatherboard they must be filled with an exterior grade filler immediately to prevent moisture uptake in the weatherboards.
- Re-prime all cut ends, mitres, notching's, borings with 2 coats of brush-applied alkyd (oil based) primer.
- Stud centres are at 600mm max, Nog centres at 450mm max.
- Leave a 2mm minimum expansion gap in the lap of rebated Shiplap profiles, to allow for expansion and contraction. Aligning the weather grooves.
- Boards must be fixed to allow for seasonal movement, with an overlap of 32mm for Shiplap profiles.
- Weatherboard fixings shall not penetrate through the flashings under any circumstances as this may jeopardise the weather tightness of the cladding system.
- Timber weatherboards are designed to accommodate thermal, seismic and moisture related movement in the boards laps. Each weatherboard is single nailed so that the weatherboards can expand, contract and move independently of each other. KLC does not recommend the use of any sealant/glue which inhibits the natural and ongoing movement of the weatherboard.

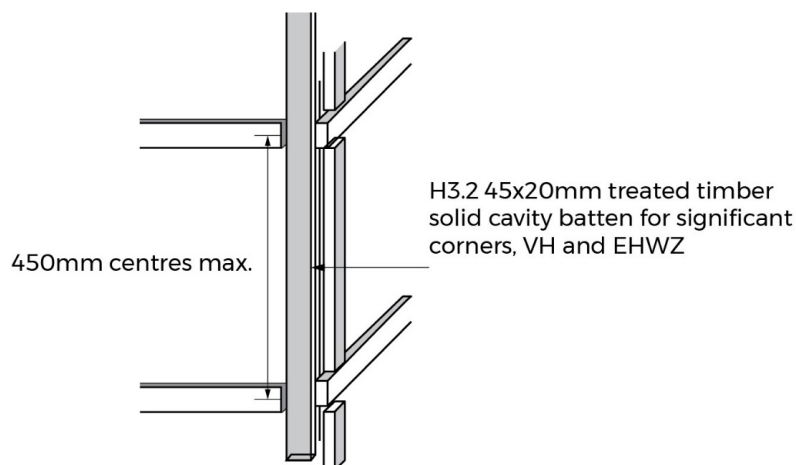

# 6 Installation Details for Generation II

## JOINTS AND CUTS

All cut ends, drill holes, rebates and notches must be resealed immediately with a suitably approved product. eg an Alkyd Primer

End sealing can also be achieved by the application of 2 coats of brush-applied, quality Alkyd (oil based) primer which are allowed to dry between coats.

When products are joined a scarf or splay joint is to be used. These must face away from the prevailing weather. Alternatively, a corrosion- resistant soaker must be applied.

## 6.3 BOTTOM OF CLADDING

There are differing requirements for the clearance between cladding, ground and pavers.

Wall cladding and concrete slabs:

- Weatherboards must overlap the floor structure by no less than 50mm.
- Ensure the bottom of the weatherboard is no closer than 150mm from a paved/concrete ground surface or 225mm from an uncovered ground surface. Ensure the end is completely sealed with a quality primer
- Overlap the concrete slab by a minimum of 50mm.
- Direct fix cladding must have a minimum horizontal off-set of 6mm to prevent moisture capillary action.
- Wall Cladding on suspended timber floors:
  - With drained cavities there will be no direct connection between the sub floor spaces and the drained cavities.
  - Direct fix cladding must have a minimum horizontal offset of 6mm to prevent moisture capillary action.
  - With drained cavity systems care must be taken to ensure air from the sub-floor space cannot enter the cavity.

**Refer to detailed drawings section**

## 6.4 WALL PENETRATION

Prior to the installation of doors and windows the following must be completed:

- Wall underlay shall be cut and dressed on all sides.
- Flexible flashing tape shall be applied to the head and sill framing.

Windows, doors and other penetration openings shall have a flexible air seal to minimise the risk of air flow carrying moisture into the building wall.

The air seal shall:

- Be between the reveal or the frame and the wrapped opening.
- Installed over closed cell polyurethane foam, backing rod or similar product.
- Be made of:
  - a. Self-expanding polyurethane foam
  - b. A sealant complying with Type F, class 20LM of ISO 11600 or a low modulus Type II Class A Federal Specification TT-S-00230C.

**Refer to detailed drawings section**

# 6 Installation Details for Generation II

## 6.5 WINDOW AND DOOR HEADS

When installed the flange forming the window, door facing must overlap the cladding material or the back flashing by a minimum of:

- 10mm on jambs
- 8mm on sills

### Direct Fix Weatherboards:

When installing direct fix weatherboards, window and doors shall have a 5mm stand-off from the flange to the weatherboard to allow for air equalisation. The gap is to be sealed or trimmed down the jamb but left open along the sill.

Head flashings must have a 50mm bead of sealant installed between the weatherboard and each end of the head flashing.

**Refer to detailed drawings section**

## 6.6 CUTTING AND END SEALING

- All cut ends, drill holes, rebates and notches must be resealed immediately with a suitably approved product. eg an Alkyd Primer (oil-based)
- End sealing can also be achieved by the application of 2 coats of brush-applied, quality Alkyd oil-based primer which are allowed to dry between coats.
- Avoid joining KLC Generation II H3.2 vertical weatherboards whenever possible, but if unavoidable use a 45 degree angle joint directly over nogs. The top board overlapping the bottom board
- Use one single nail through the overlapping board to join.

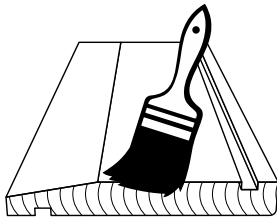

Two coats of an Alkyd (oil based) primer or end sealer.

# 6 Installation Details for Generation II

## 6.7 SOAKERS AND FLASHINGS

Soakers and flashings can be Galvanised Steel, Aluminium, Stainless Steel (304) or Copper. All these materials are compatible with the KLC Generation II H3.2 profiles. These are safe to use with MicroPro treated products.

Soakers and flashings must be fixed in accordance with the NZS3604:2011 and Acceptable Solution E2/AS1.

Soakers must have a minimum of 15mm overlap from the corner or join. Flat soakers to be used on all butt joins.

NZS 3604:2011 section 4 and Table 6.12 outline durability for flashings. Section 9 of E2/AS1 outlines flashing design and fabrication details.

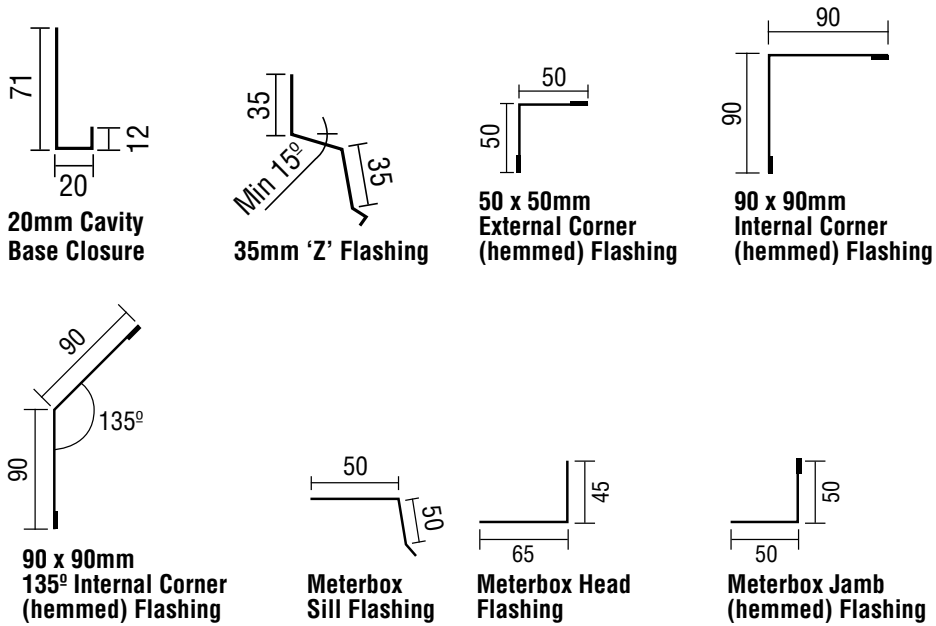

### General Sealing of Head Flashing

*Note: May also use wall underlay lapped over flashing upstand in lieu of flexible flashing tape.*

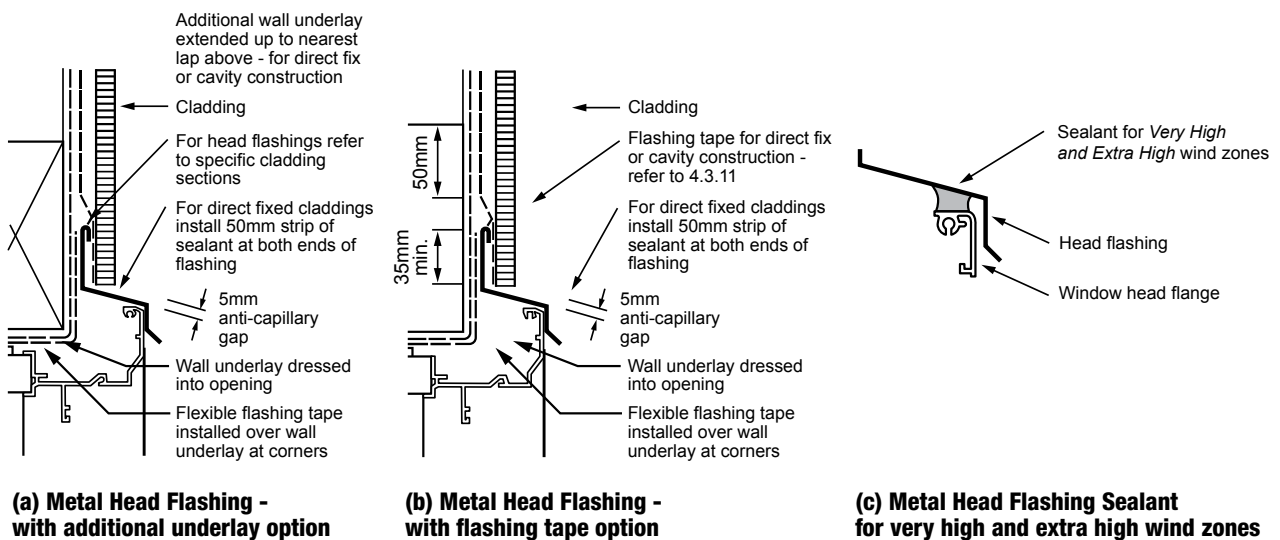



# 6 Installation Details for Generation II

## 6.8 BOX CORNERS FOR EXTERNAL CORNERS

The KLC Generation II H3.2 Box Corner profile range includes an internal and external box corner piece 98x18 and an external and internal piece 85x18. Both being a two piece system.

- Position the Box Corners and nail over the KLC Generation II H3.2 vertical shiplap weatherboard using a 75x3.15mm galvanised or stainless steel jolt head nails at approximately 450mm centres, taking care to not nail through two layers of weatherboard.
- Ensure all cut end are sealed immediately with a suitably approved product. eg an Alkyd Primer
- The boxed corner must provide a minimum cover of 50mm from the cut end of the weatherboards. Boxed corners are made weather proof by the following method:

**Refer to detailed drawings section**

## 6.9 INTERNAL CORNERS

Internal corners must be made water tight by the use of corrosion-resistant flashings which shall be fitted behind the weatherboards on all internal corners.

**Refer to detailed drawings section**

## 6.10 GENERAL INTER-STOREY JUNCTIONS

Inter-storey junctions in cladding over drained cavity systems shall be formed for walls over 2 storeys or 7 metres in height.

Cavity battens used, can run the full height of the wall, however walls over 7 metres or 2 storeys must have an Inter-Storey Junction. This is formed to allow for the management of moisture handled by the cavity to be directed to the outside of the building.

The Junction must have:

- A Minimum 15mm drip edge
- A minimum 5mm capillary gap Flashing used must have:
- A Minimum 15 degree slope
- A minimum 35mm up stand
- A minimum 35mm cover over the weatherboard

### Internal Corners for Horizontal or Vertical Weatherboards

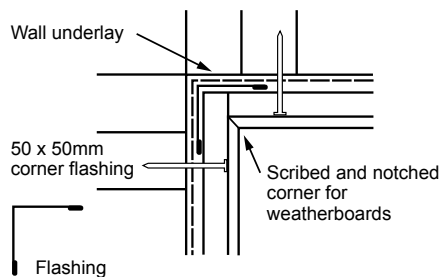

**(a) Direct Fix - Internal Butt Corner**

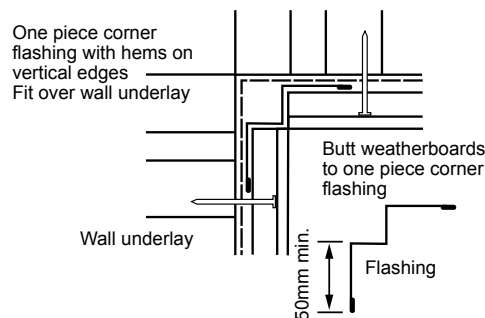

**(b) Direct Fix - Internal Corner Flashing**

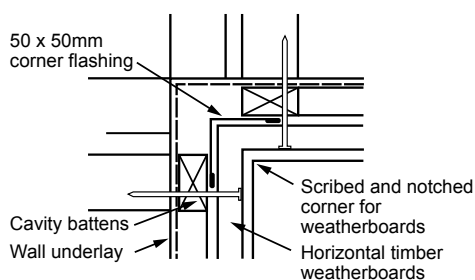

**(c) Cavity - Internal Butt Corner**

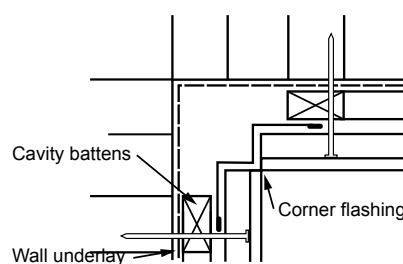

**(d) Cavity - Internal Corner Fillet**

# 7 Fascia

As an alternative to nail fixing, fascia can be screwed onto rafter ends as wide as is practical with wide head (10mm) Stainless steel screws, slightly countersunk. Screws should be a min. 75mm long.

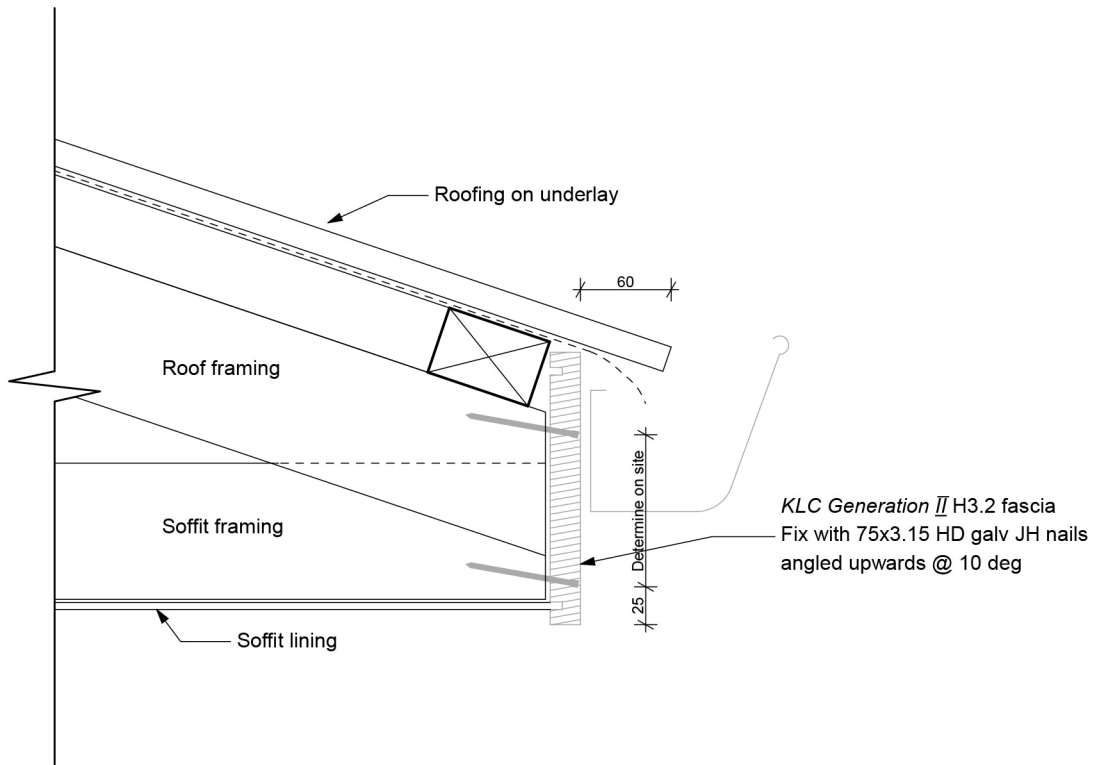

# 8 Painting Requirements

KLC Generation II H3.2 products have a premium factory applied alkyd primer and undercoat applied in two separate coats.

- All painting must be carried out in a good tradesman-like manner and in accordance with AS/NZS 2311 2009. Please also refer to “BRANZ Good Practice Guide to Exterior Coating”.
- **Do not** paint Generation II H3.2 weatherboards if the moisture content is over 15%.
- Remove any dirt and surface contamination by sanding and dusting down. Prime immediately any exposed bare timber with a premium exterior alkyd primer.
- Darker colours will absorb heat from the sun and may cause excessive movement, distortion, cracking and possible resin bleed. Light colours reflect the sun's heat.
- The KLC warranty will be void if dark colours with a Light Reflectance Value (LRV) less than 45 are used.
- KLC Limited recommend an application of two coats of quality exterior house paint at a rate no greater than 12m<sup>2</sup> per litre per coat.

## Top Coat Light Reflectance Values as recommended by KLC



The significance of Light Reflectance Values is now being recognized by the building industry.

When paint is exposed to sunlight it absorbs and reflects radiant heat (as well as UV light). It's not only radiant heat warming up the paint film that is the problem. Damage is caused by temperature changes (i.e. from hot sun to cloudy sky) causing the paint film to go through a process of heating up then cooling down again resulting in changes in dimensional stability of the timber substrate. Increases in the core temperature of the timber substrate can also cause resins to mobilise and leach through the paint film. This is known as resin bleed.

The other factor to consider is UV light, the other part of the sun's spectrum. When UV light hits the paint film it causes the release of free radicals that can damage the surface.

Light paint colours with a high light reflectance (and therefore a high LRV over 45) allow less free radicals to be released, which means the paint film and substrate will last longer. Correspondingly dark colours with a lower light reflectance allow more free radicals to be absorbed therefore causing more damage to the surface and resulting in reduced life for the paint film.

KLC recommend choosing a colour with an LRV of 45 or higher for use on all KLC timber products coated with PPG 839 alkyd primer.

# 9 Maintenance

It is the responsibility of the home owner to ensure that annual maintenance is carried out. Maintenance should be carried out every 12 months. In some cases, this may be required more regularly eg. sea spray

## Maintenance Checklist

1. Wash all exterior surfaces using a low-pressure wash system to remove dust, dirt and other contaminants.
  - Do not use a high pressure washing system eg water blaster
  - If the washing does not remove stubborn areas of mold or dirt use a soft brush or broom and an appropriate cleaning agent to remove these deposits. Check with the paint manufacturer and read the directions on the product to apply the cleaning agent.
  
2. Once the building is clean and the surfaces have been inspected for damage, wear and tear and paint coating degrade then repairs and must be undertaken immediately.
  - If the paint surface has been damaged then:
    - Remove all damaged paint, sand back if required
    - Apply a quality primer on any bare timber
    - Once the primer has dried apply 2 top coats of a quality top coat paint.
  
3. It is a general rule that timber weatherboard homes should be repainted every 10 years if the initial coating product used was of good quality, delivering a good quality coating finish. In some cases repainting may be required earlier depending on condition and exposure to harsher elements.

# 10 Health and Safety

Health and safety precautions should be adhered to when working with all wood products.

Machine tools should be fitted with dust extractors and work areas should be kept clean.

If dust levels exceed Work Safe New Zealand Standards, the wearing of a dust mask (AS/NZS 1715 & AS/NZS 1716) and protective eyewear (AS/NZS1336 & AS/NZS 1337) is recommended.

Storage and work areas should be adequately ventilated.

# 11 Detailed Drawings

## DRAWINGS DIRECTORY

### Direct Fix

D1.1	Foundation, Timber Floor	23
D1.2	Foundation, Concrete Floor	23
D1.3	Door Sill, Timber Floor	24
D1.4	Door Sill, Concrete Floor	24
D1.5	Window Head	25
D1.6	Door Jamb	25
D1.7	Window Sill	26
D1.8	Window Jamb	26
D1.9	Soffit Junction	27
D1.10	External Box Corner	28
D1.11	Internal Box Corner	28
D1.13	Meter Box Head	29
D1.14	Meter Box Jamb	29
D1.15	Meter Box Sill	29
D1.16	Pipe Penetration	30
D1.17	Apron	30
D1.18	Parapete	31
D3.6	Direct Fixing	31

### Cavity Fix Application

D2.1	Foundation, Timber Floor	32
D2.2	Foundation, Concrete Floor	32
D2.3	Door Sill, Timber Floor	33
D2.4	Door Sill, Concrete Floor	33
D2.5	Window Head	34
D2.6	Window Jamb	34
D2.7	Window Sill	35
D2.8	Soffit Junction	35
D2.9	External Box Corner	36
D2.10	Internal Box Corner	36
D2.11	Meter Box Head	37
D2.12	Meter Box Jamb	37
D2.13	Meter Box Sill	38
D2.14	Nil Soffit	38

# 11 Detailed Drawings

## D1.1 Foundation, Direct Fix, Timber Floor

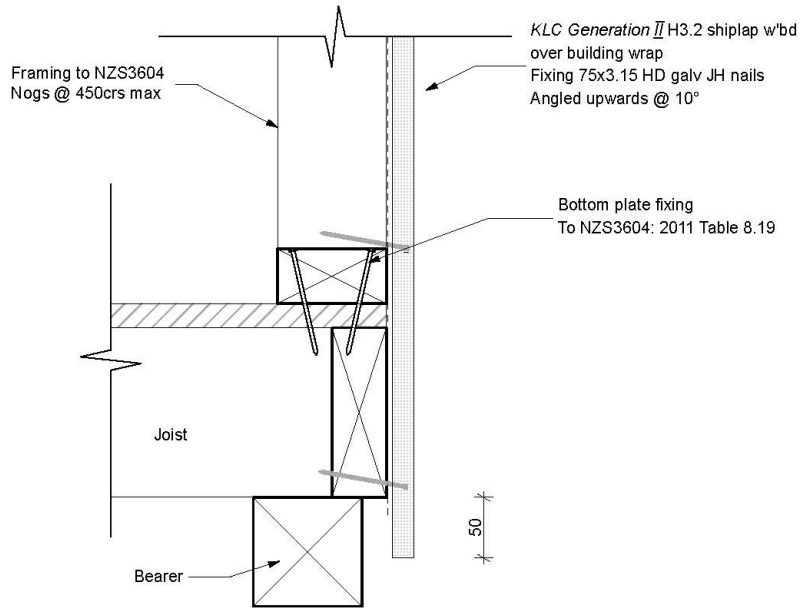

## D1.2 Foundation, Direct Fix, Concrete Floor

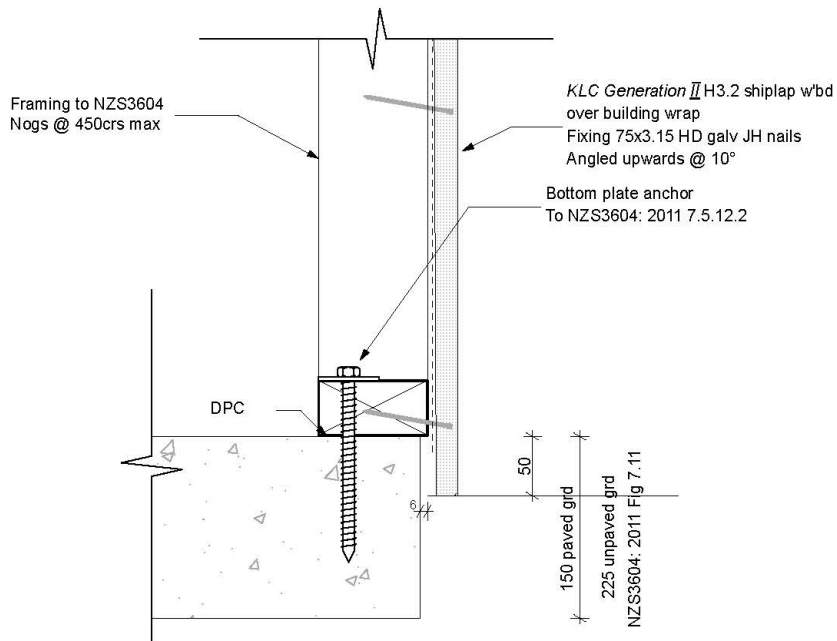

# 11 Detailed Drawings

## D1.3 Sill, Direct Fix, Timber Floor

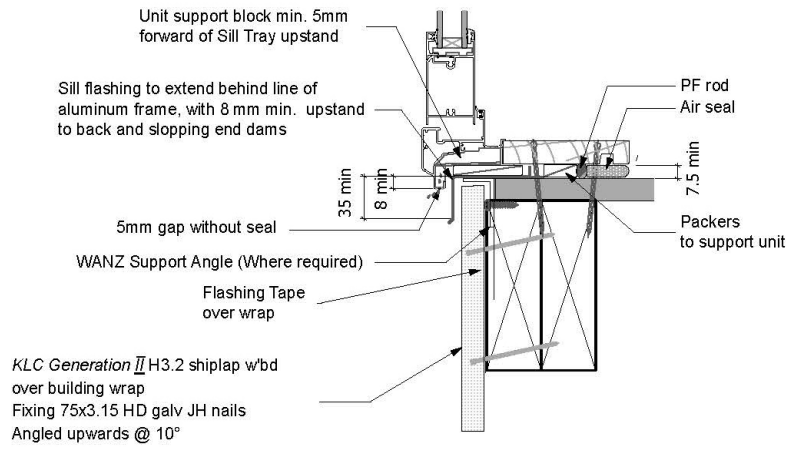

## D1.4 Sill, Direct Fix, Concrete Floor

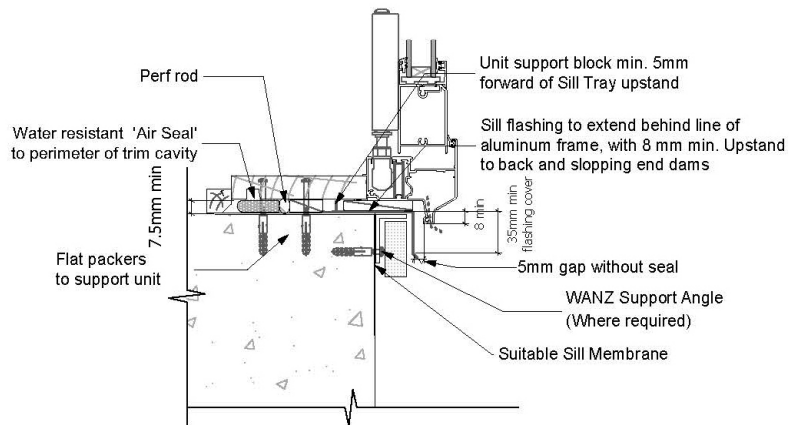



# 11 Detailed Drawings

## D1.5 Window Head, Direct Fix

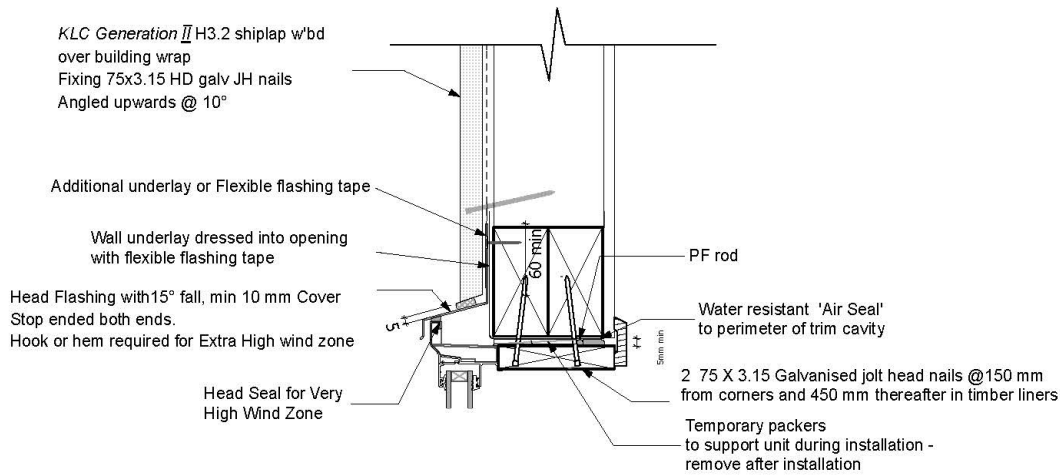

## D1.6 Door Jamb, Direct Fix

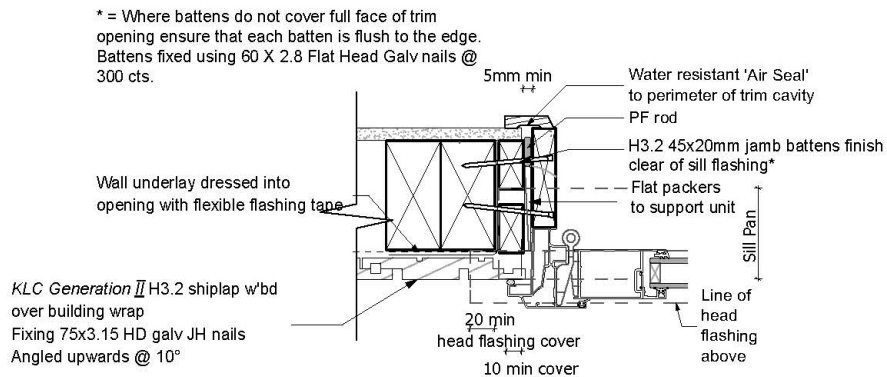

# 11 Detailed Drawings

## D1.7 Window Sill, Direct Fix

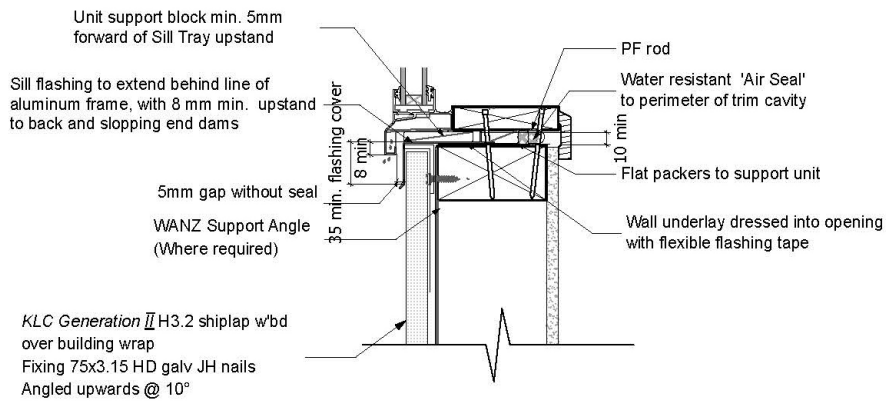

## D1.8 Window Jamb, Direct Fix

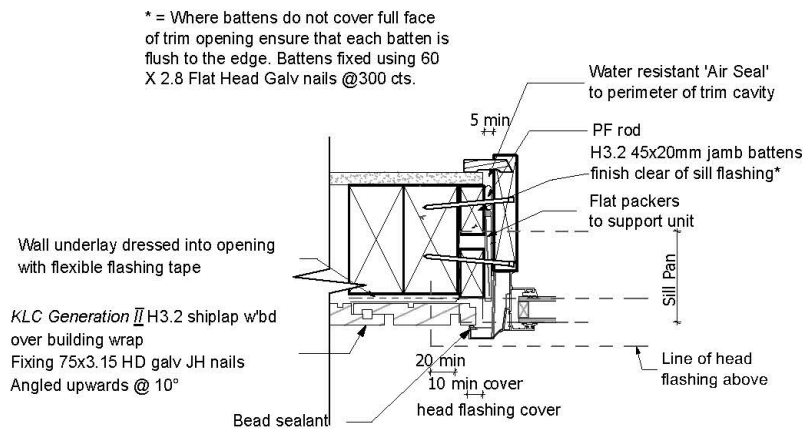

# 11 Detailed Drawings

## D1.9 Soffit Junction, Direct Fix

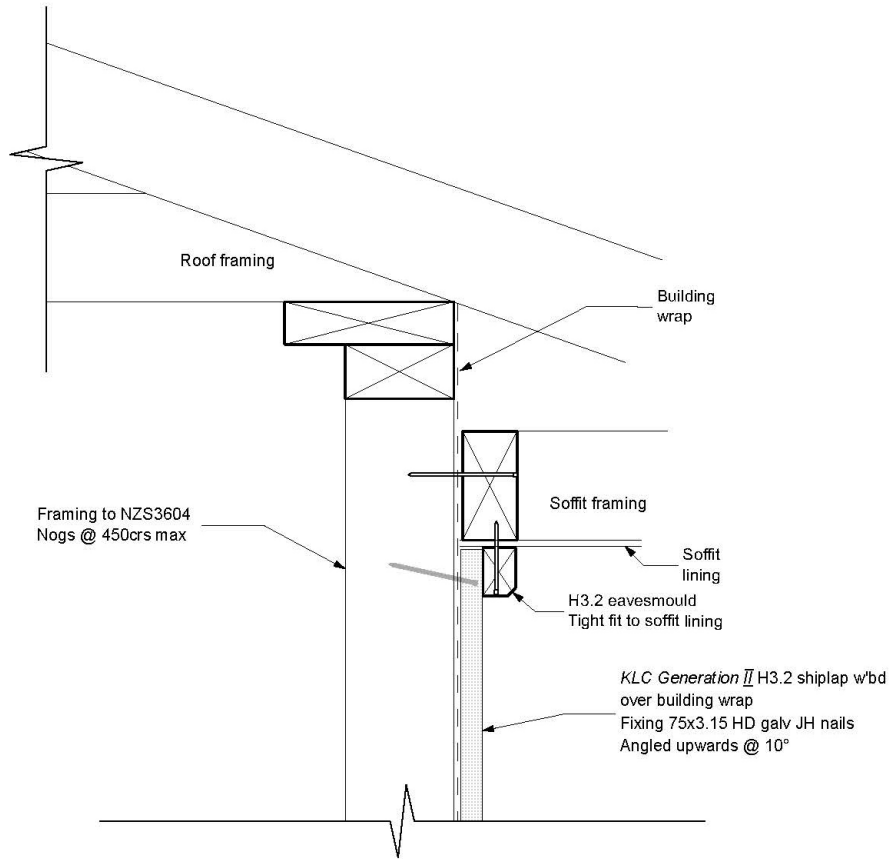

## D1.10 External Box Corner, Direct Fix

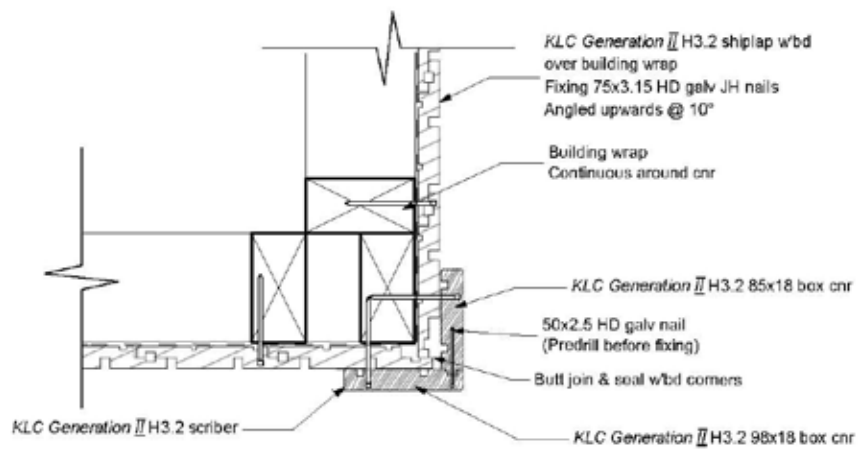

# 11 Detailed Drawings

## D1.11 Internal Box Corner, Direct Fix

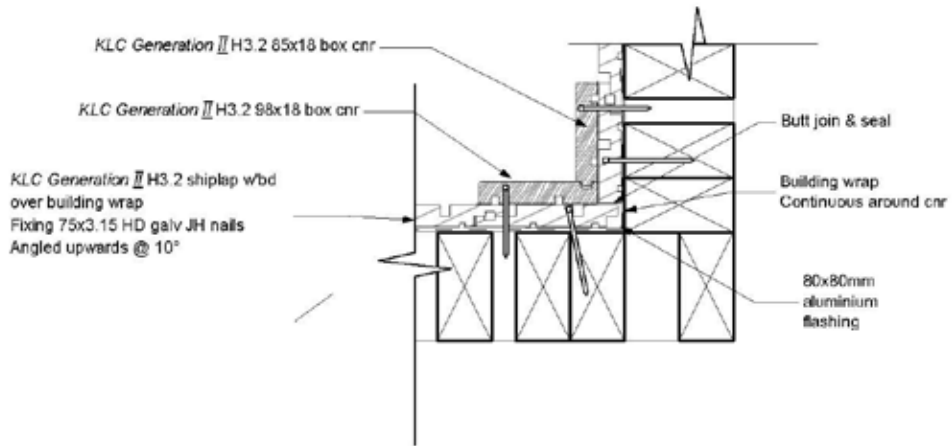

## D1.13 Meter Box Head, Direct Fix

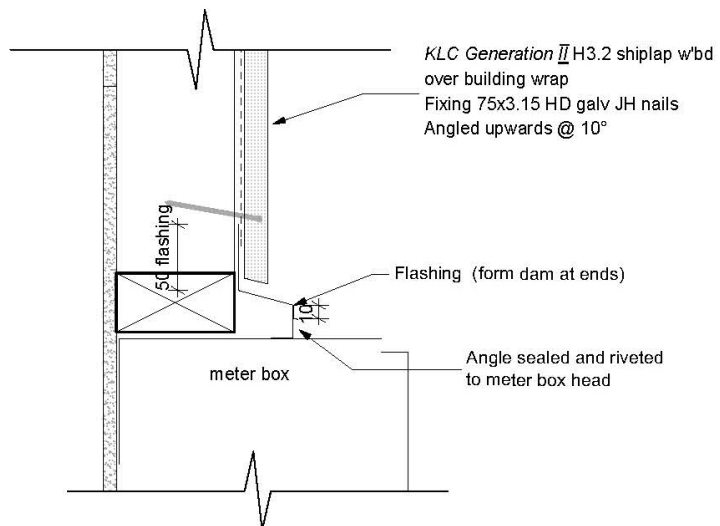

# 11 Detailed Drawings

## D1.14 Meter Box Jamb, Direct Fix

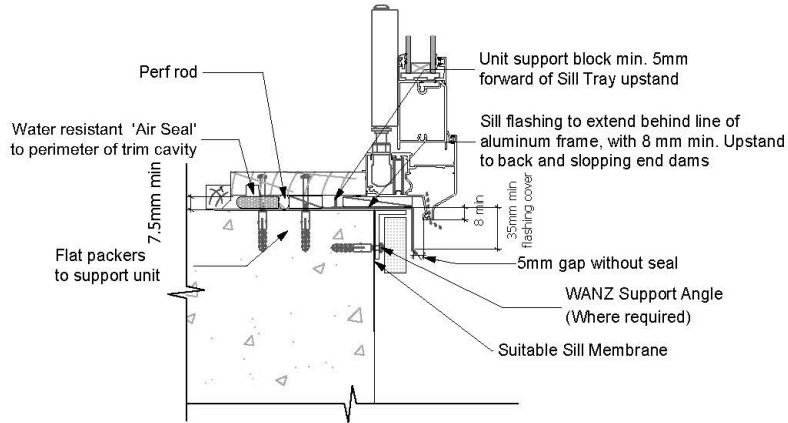

## D1.15 Meter Box Sill, Direct Fix

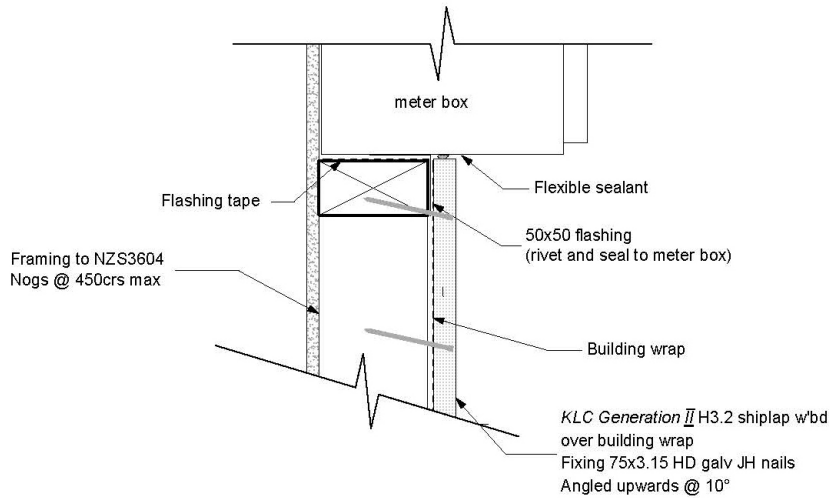

# 11 Detailed Drawings

## D1.16 Pipe Penetration, Direct Fix

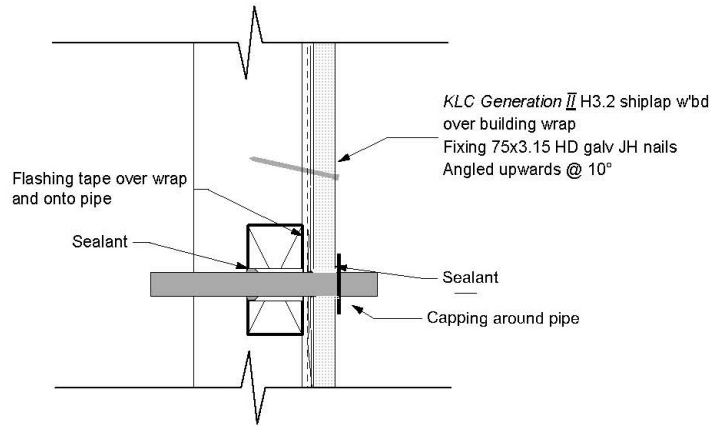

## D1.17 Apron, Direct Fix

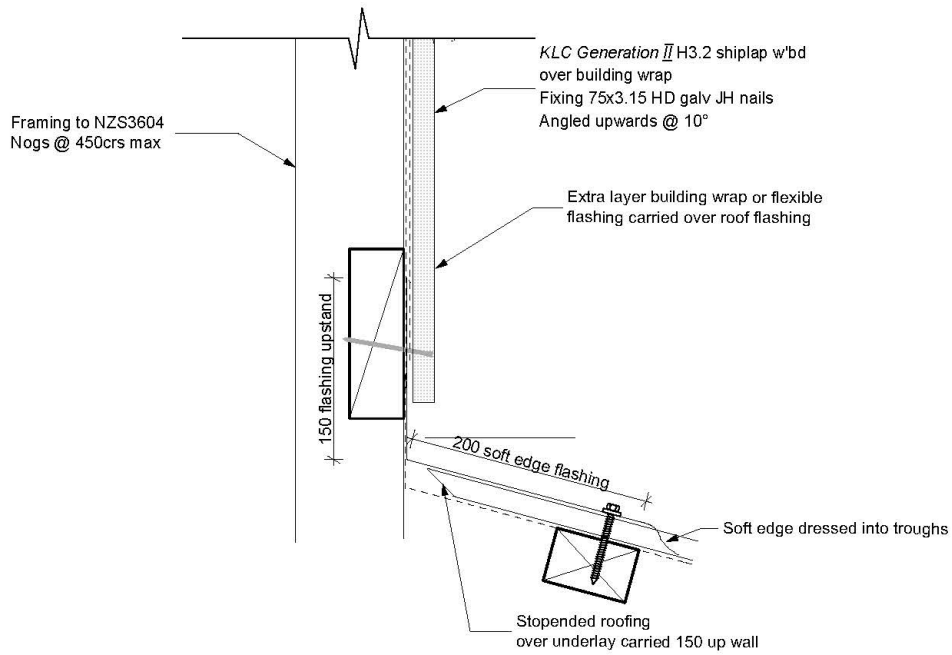

# 11 Detailed Drawings

## D1.18 Parapete, Direct Fix

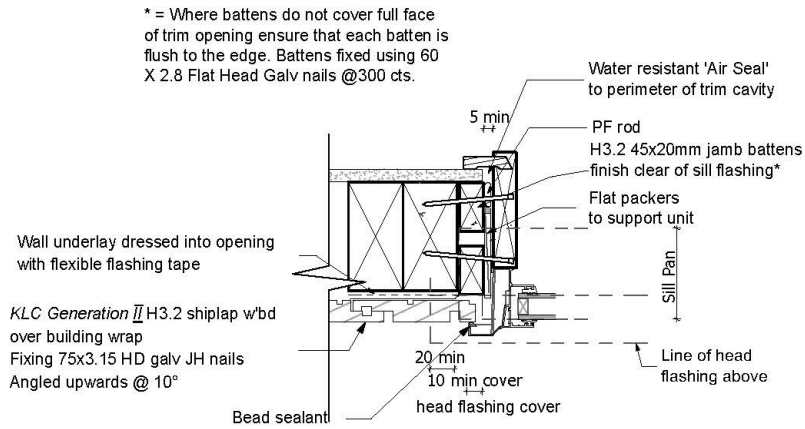

## D3.6 Fixing Detail

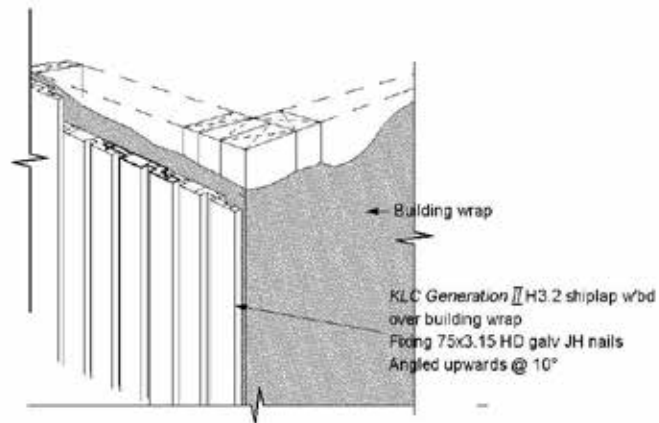

# 11 Detailed Drawings

## D2.1 Cavity Fix, Foundation, Timber Floor

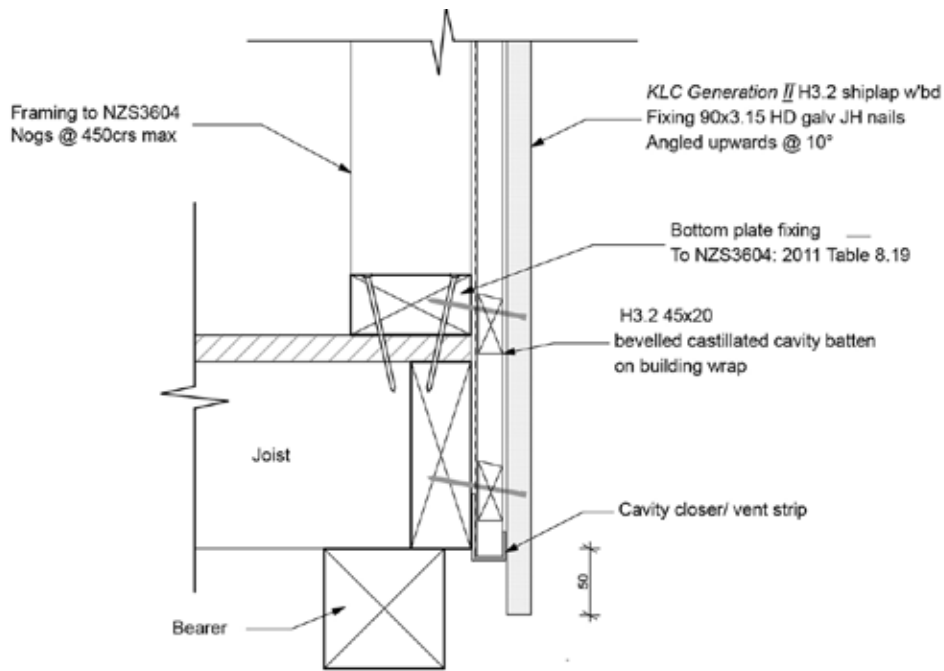

## D2.2 Cavity Fix, Foundation, Concrete Floor

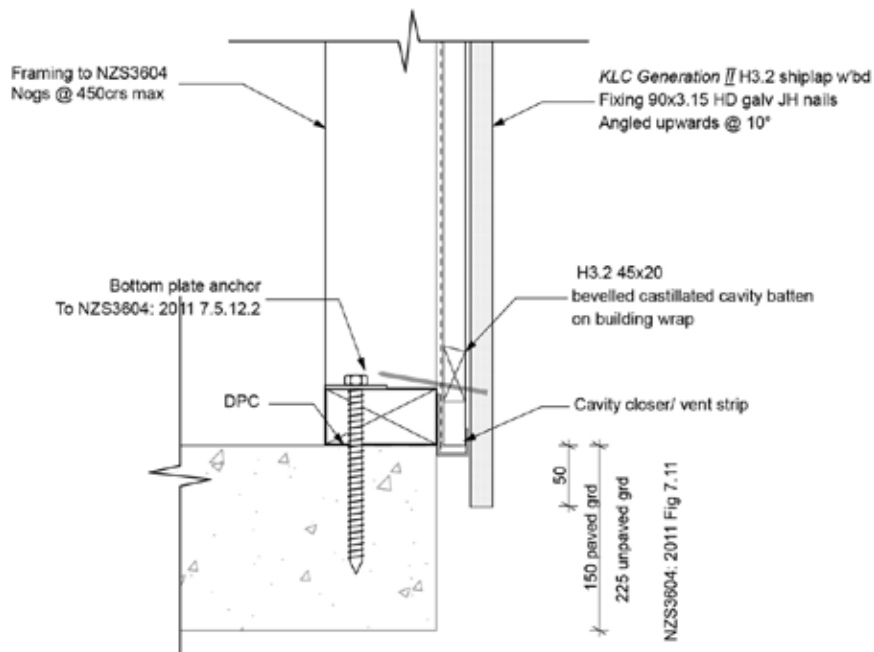



# 11 Detailed Drawings

## D2.3 Cavity Fix, Door Sill, Timber Floor

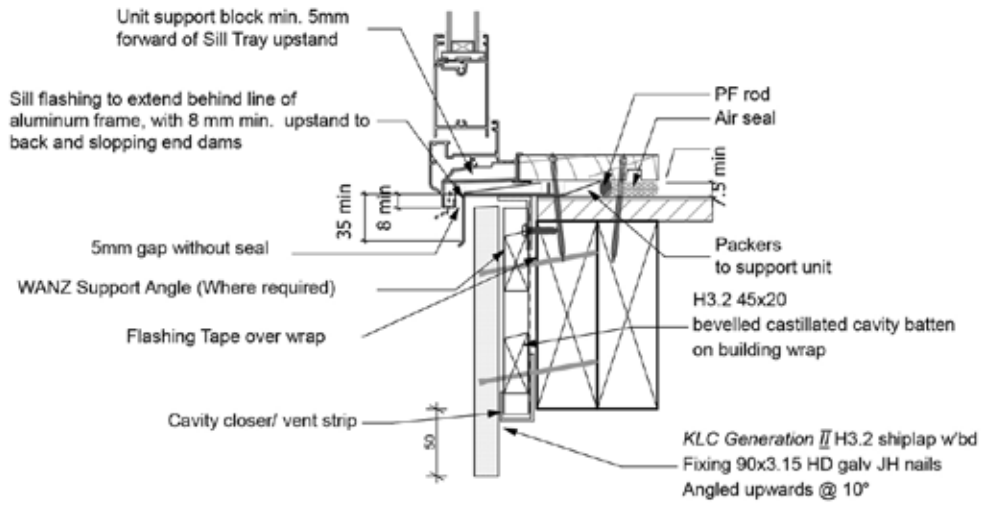

## D2.4 Cavity Fix, Door Sill, Concrete Floor

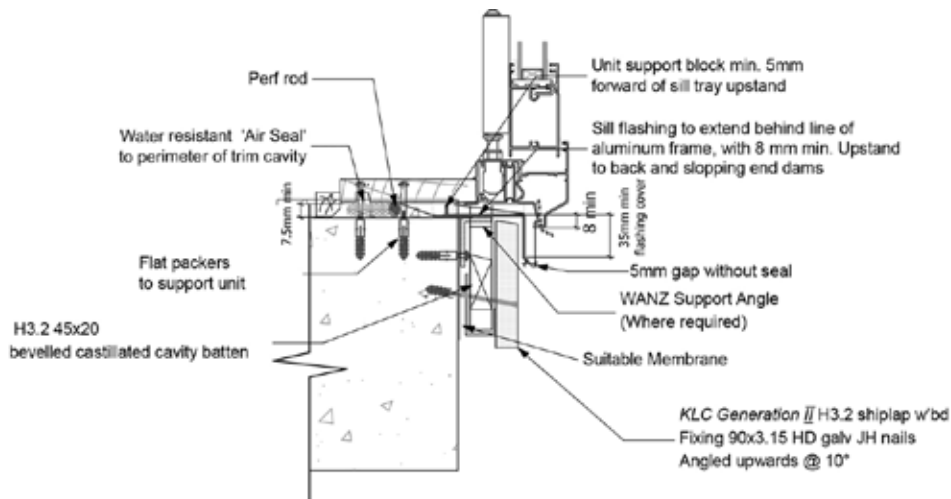

# 11 Detailed Drawings

## D2.5 Cavity Fix, Window Head

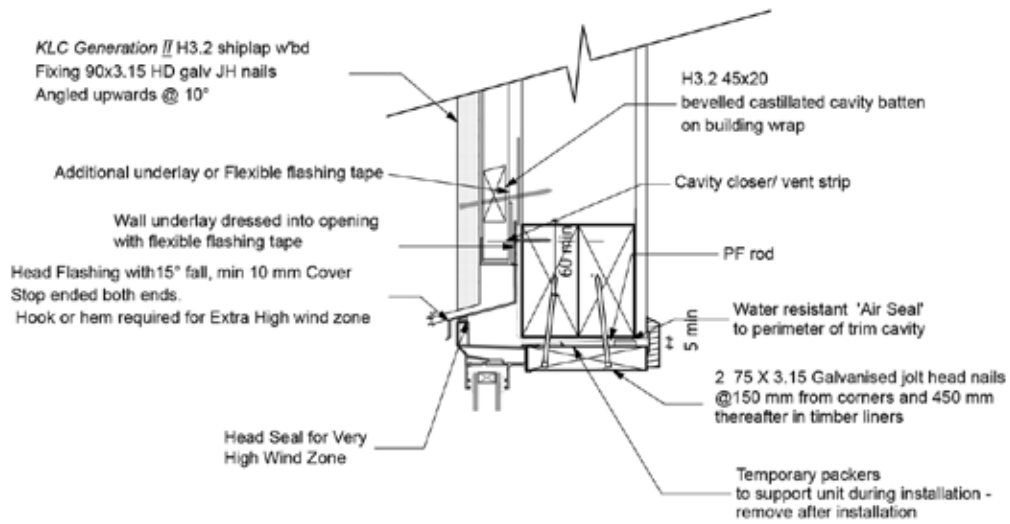

## D2.6 Cavity Fix, Window Jamb

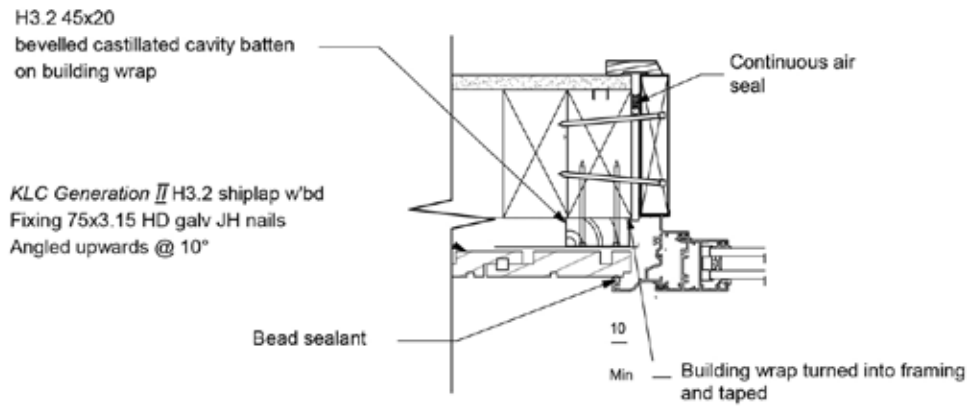

# 11 Detailed Drawings

## D2.7 Cavity Fix, Window Sill

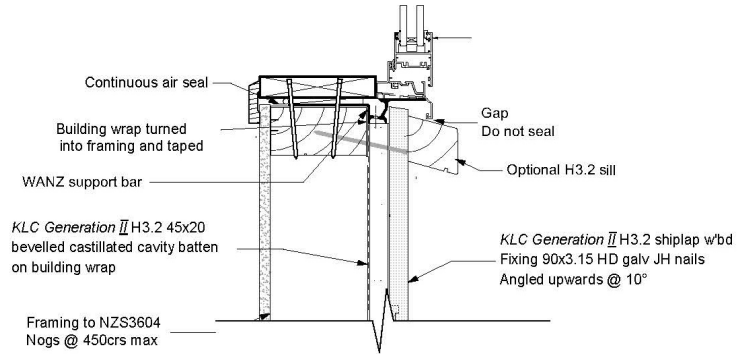

## D2.8 Cavity Fix, Soffit Junction

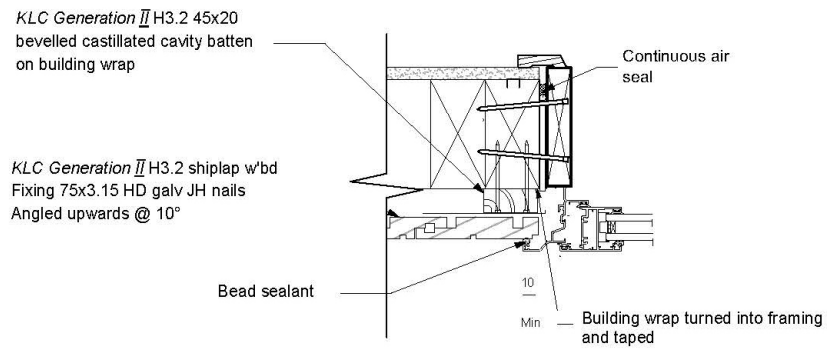

# 11 Detailed Drawings

## D2.9 Cavity Fix, External Corner

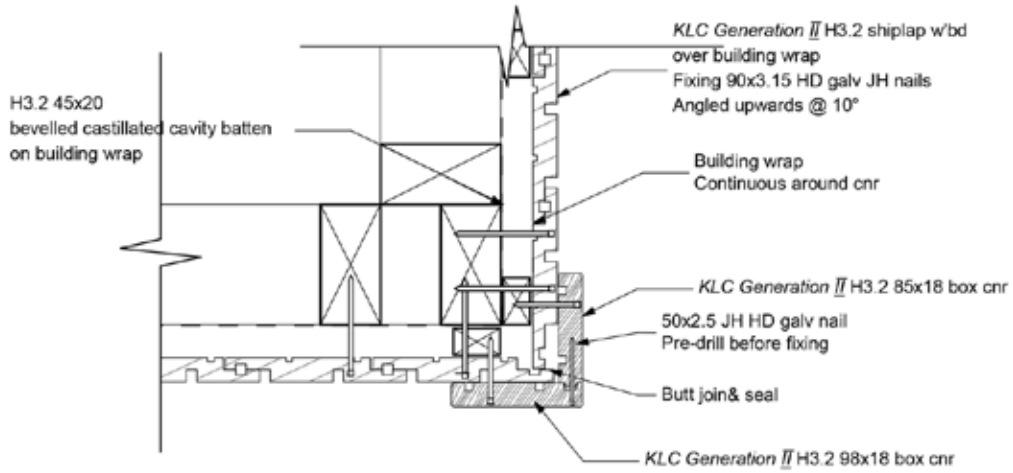

## D2.10 Cavity Fix, Internal Corner

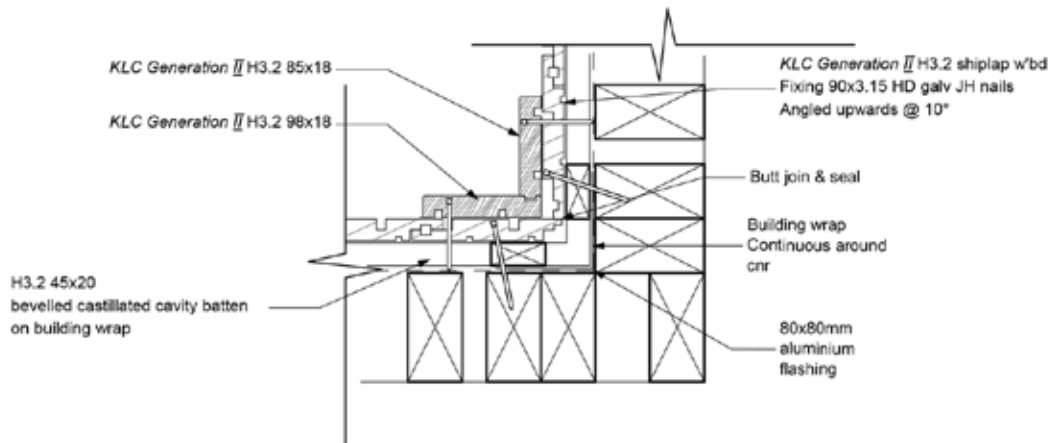

# 11 Detailed Drawings

## D2.11 Cavity Fix, Meter Box Head

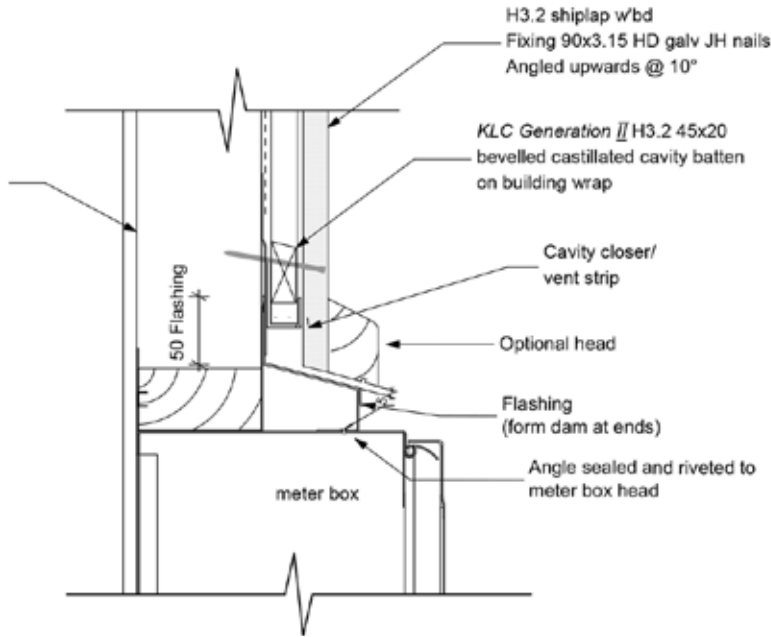

## D2.12 Cavity Fix, Meter Box Jamb

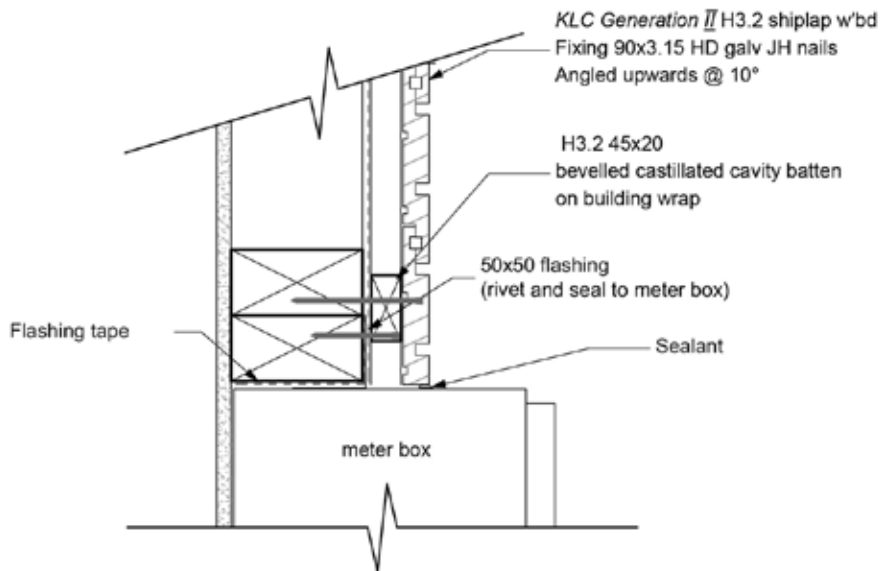

# 11 Detailed Drawings

## D2.13 Cavity Fix, Meter Box Sill

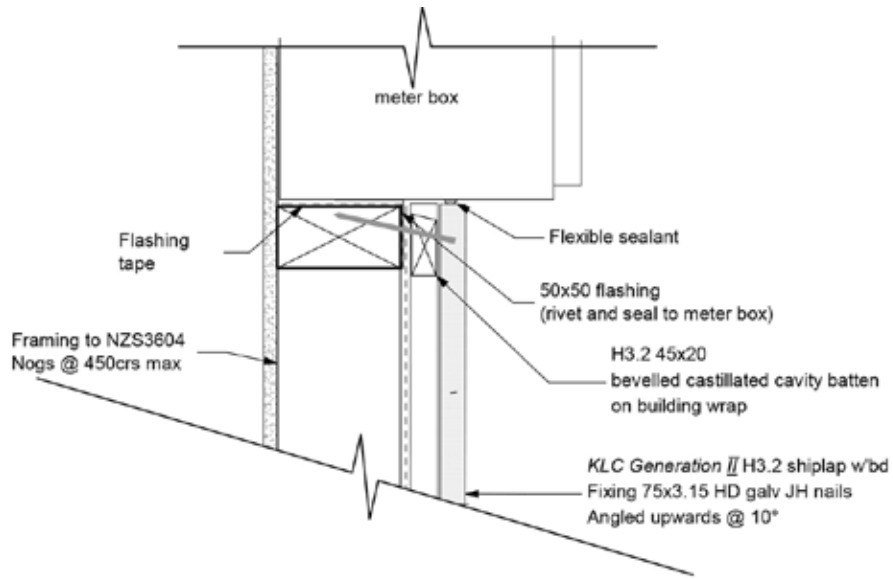

## D2.14 Cavity Fix, Nil Soffit

